



4x4 HDMI Matrix Switcher with Full 3D Support



P/N: AV-GM07A3-S1



Safety and Notice

The **AV-GM07A3-S1 4x4 HDMI Matrix Switcher with Full 3D Support** has been tested for conformance to safety regulations and requirements, and has been certified for international use. However, like all electronic equipments, the **AV-GM07A3-S1** should be used with care. Please read and follow the safety instructions to protect yourself from possible injury and to minimize the risk of damage to the unit.

- Follow all instructions and warnings marked on this unit.
- Do not attempt to service this unit yourself, except where explained in this manual.
- Provide proper ventilation and air circulation and do not use near water.
- Keep objects that might damage the device and assure that the placement of this unit is on a stable surface.
- Use only the power adapter and power cords and connection cables designed for this unit.
- Do not use liquid or aerosol cleaners to clean this unit. Always unplug the power to the device before cleaning.



TABLE OF CONTENTS

INTRODUCTION.....	1
FEATURES.....	1
PACKAGE CONTENTS	1
SPECIFICATIONS	2
PANEL DESCRIPTIONS.....	3
DIP SWITCH.....	5
HARDWARE INSTALLATION.....	7
CONNECTION DIAGRAM	7
OPERATION AND IR CONTROL.....	8
Source Side.....	8
EDID LEARNING	15
IR DISCRETE CODE	17
FAQ	19
WARRANTY	21

INTRODUCTION

The **AV-GM07A3-S1 4x4 HDMI Matrix Switcher with Full 3D Support** provides the most flexible and cost effective solution in the market to route high definition video sources plus multi-channel (up to 7.1 channel) digital audio from any of the four HDMI sources to the any four displays at the same time. This solution is well suited for use in home theater, conference room presentation systems, or other similar setting or application.

FEATURES

- Support HDMI Deep Color & full 3D
- Support 3D video Format
- HDCP compliant
- Allows any source to be displayed on multiple displays at the same time
- Allows any HDMI display to view any HDMI source at any time
- Supports 7.1 channel digital audio
- Supports default HDMI EDID and learns the EDID of displays
- The matrix master can switch every output channels to any HDMI inputs by push button, IR remote control, or RS-232 control

PACKAGE CONTENTS

- 1x AV-GM07A3-S1
- 1x DC 5V 6A in-line with C5 power cord
- 1x Rack-mounting ear set
- 1x IR remote control
- 1x Installation CD
- 1x User Manual

SPECIFICATIONS

Model Name	AV-GM07A3-S1	
Technical		
Role of usage	True 4x4 matrix	
HDMI compliance	Support HDMI Deep Color & full 3D	
HDCP compliance	Yes	
Video bandwidth	Single-link 225MHz [6.75Gbps]	
Video support	480i / 480p / 720p / 1080i / 1080p60 12-bit color	
Audio support	Surround sound (up to 7.1ch) or stereo digital audio	
ESD protection	[1] Human body model — ±19kV [air-gap discharge] & ±12kV [contact discharge] [2] Core chipset — ±8kV	
PCB stack-up	4-layer board [impedance control — differential 100Ω; single 50Ω]	
Input	4x HDMI + 1x RS-232	
Output	4x HDMI	
HDMI Input selection	Push button / IR remote / RS-232	
IR remote control	Electro-optical characteristics: $\theta = 25^\circ$ / Carrier frequency: 36~40kHz	
HDMI connector	Type A [19-pin female]	
RJ-45 connector	WE/SS 8P8C with 2 LED indicators [TMDS & DDC channels]	
RS-232 connector	DE-9 [9-pin D-sub female]	
DIP switch	[SW1~SW4] 2-pin for EDID learning, audio/video settings [SW Main] 4-pin operation mode & firmware update	
Mechanical		
Housing	Metal enclosure	
Dimensions (L x W x H)	Model	1RU - 440 x 110 x 44mm [1'6" x 4.3" x 1.7"]
	Package	494 x 225 x 70mm [1'6" x 8.9" x 2.8"]
	Carton	510 x 380 x 252mm [1'7" x 1'2" x 10"]
Weight	Model	1075g [2.4 lbs]
	Package	2200g [4.9 lbs]
Fixedness	1U rack-mount with ears and wall hanging holes	
Power supply	5V 6A DC	
Power consumption	20 Watts [max]	

Operation temperature	0~40°C [32~104°F]
Storage temperature	-20~60°C [-4~140°F]
Relative humidity	20~90% RH [no condensation]

PANEL DESCRIPTIONS

Front Panel

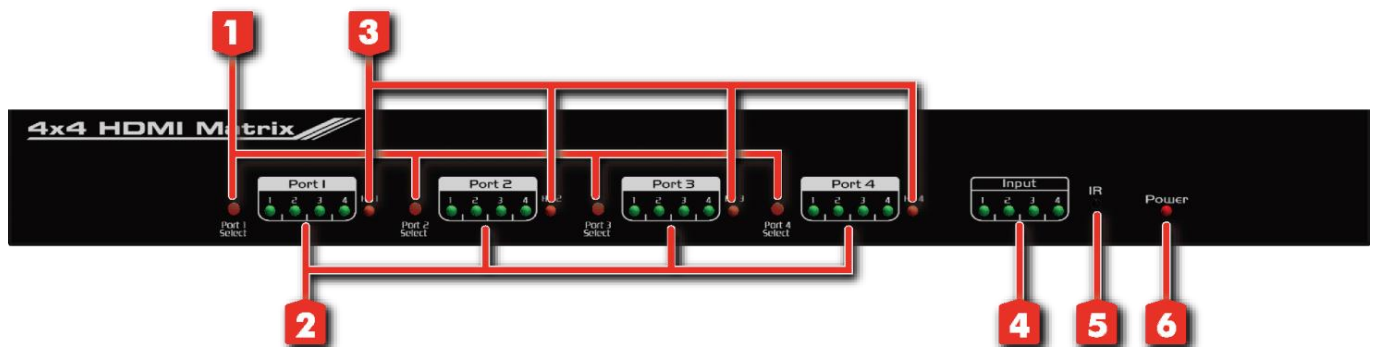

1. **Port 1-4 Select:** Push button for selecting input channels
2. **Port 1-4:** Input source channels mapping LED for each output channel
3. **HP 1-4:** Connection status indicator for each output channel
4. **Input:** Input source indicator
5. **IR:** IR receiver
6. **Power:** Power indicator

Rear Panel

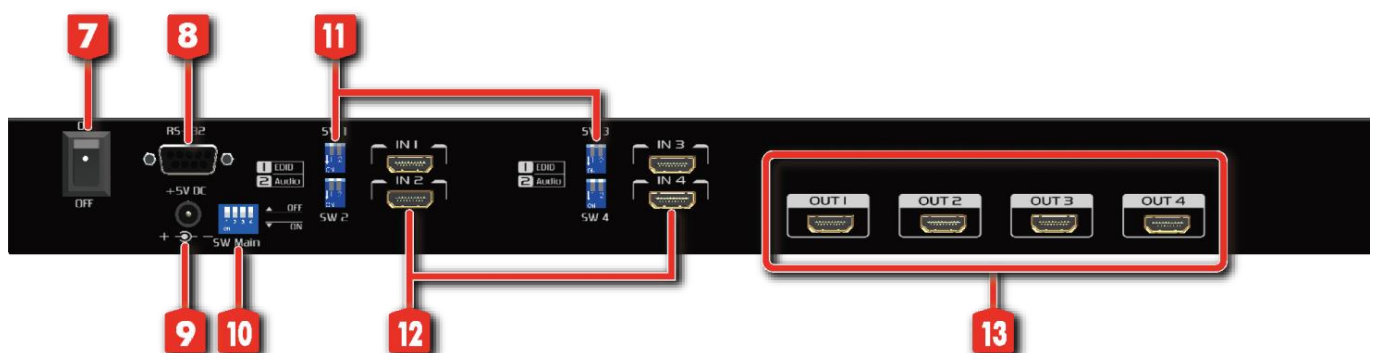

7. **Power on/off switch**
8. **RS-232:** RS-232 control port

- 9. **+5V DC:** 5V DC power jack
- 10. **SW Main:** DIP switches *(for more detail please see DIP Switch section)*
- 11. **SW 1-4:** DIP switch *(for more detail please see DIP Switch section)*
- 12. **IN 1-4:** HDMI inputs
- 13. **OUT 1-4:** HDMI outputs

DIP SWITCH

SW1-SW4 for EDID/Audio

DIP Switch Position		Video	Audio	Description
Pin#1	Pin#2			
OFF [□]	OFF [□]	Up to 1080p	Surround	Default Mode 1 1 – EDID up to 1080p video & surround sound audio output up to 7.1ch (DTS-HD Master & Dolby TrueHD)
OFF [□]	ON [□]	Up to 1080p	Stereo 2	Default Mode 2 – EDID up to 1080p video and stereo audio for basic compatibility among HDTVs
ON [□]	OFF [□]	Up to 720p/1080i	Stereo	Safe Mode 3 – EDID up to 720p/1080i video and stereo audio for basic compatibility among HDTVs
ON [□]	ON [□]	Bypass 4	Bypass 4	EDID Learning Mode 5 – for learning EDID from the display while playing any received HDMI audio format

Note

- 1 Factory default setting of [SW1]-[SW4] is pin-1 at OFF [▲] & pin-2 at OFF [▲] for 1080p video and surround sound audio.
- 2 If the HDTV shows video but without audio, please try to set audio mode to stereo.
- 3 If you encounter any unsolved audio/video output problem during system installation, please turn any [SW1]-[SW4] to pin-1 at ON [▼] & pin-2 at OFF [▲] for safe mode to select the system EDID up to 720p(1080i) video and stereo audio for system check. However, the safe mode cannot be initiated if your HDMI source is set to enforce 1080p output. In this case, please reconfigure your HDMI source to all resolution output for troubleshooting.
- 4 Bypass means the matrix will maintain playing the original format of HDMI signals in video and perhaps audio. By setting at this mode, the users may encounter compatibility issue among different kinds of HDMI sources and displays. If you cannot get the audio and/or video output normally at the system installation, please change the DIP switch setting to default mode or even safe mode to verify the functionality of the device.
- 5 To learn the EDID of HDMI display for respective HDMI source devices, please see the **[EDID Learning]** section in the next page for more information.

SW MAIN for firmware update (for technical support only)

DIP Switch Position	Pin#1	Pin#2	Pin#3	Pin#4
Normal Operation Mode 6	OFF [☐]	OFF [☐]	ON [☐]	OFF [☐]
Firmware Update Mode 7	ON [☐]	ON [☐]	OFF [☐]	OFF [☐]

Note

6 Factory default for **SW Main** is pin#1-OFF [↑], pin#2-OFF [↑], pin#3-ON [↓], & pin#4-OFF [↑].
PLEASE MAINTAIN THIS SETTING AT ANYTIME FOR REGULAR USE!

7 Sequence for firmware update

[1]. Power off the MA-5144.

[2]. Set the DIP switch position to Firmware Update Mode.

[3]. Power on the MA-5144.

[4]. Power off the MA-5144.

[5]. Set the DIP switch position to Normal Operation Mode.

[6]. Power on the MA-5144.

HARDWARE INSTALLATION

AV-GM07A3-S1

1. Connect all sources to HDMI Inputs on the 4x4 HDMI Matrix
2. Connect all outputs to HDMI devices
3. Connect the +5V 6A DC power supply to the 4x4 HDMI Matrix
4. Power on the 4x4 HDMI Matrix MX-5144KH

CONNECTION DIAGRAM

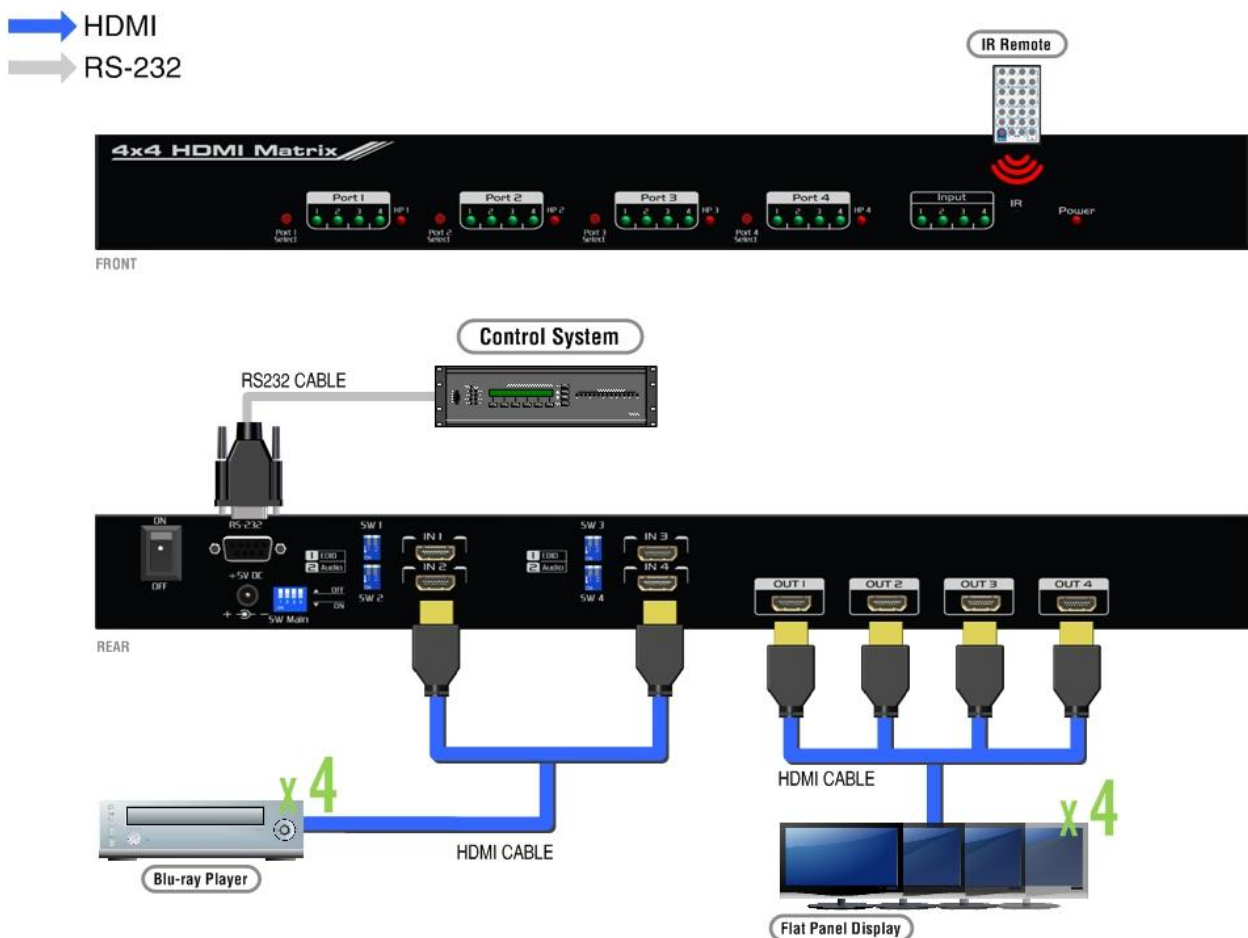

OPERATION AND IR CONTROL

Source Side

Method A: Push-in Button

Push the red switch button on output port to select which port to be changed.

Method B: IR Remote Control

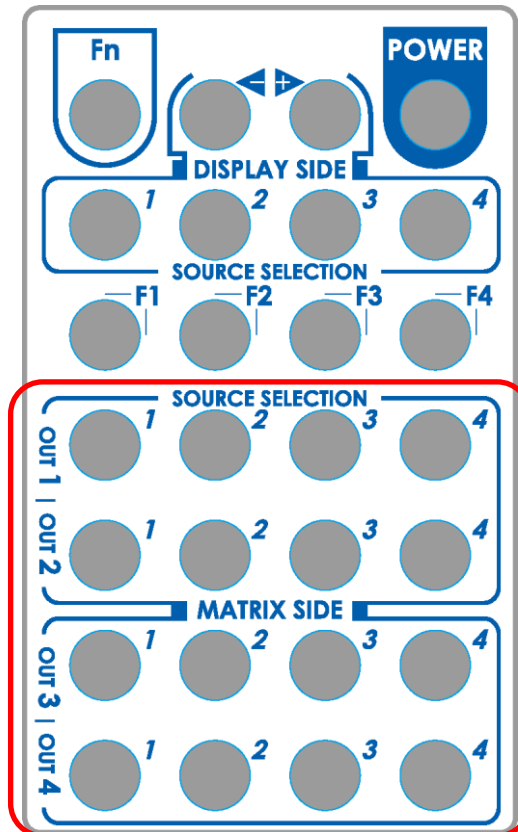

Choose the output port you want to make channel switch from OUT1 to OUT4 then press 1-4 channel button to choose the HDMI input source shown on the chosen output display.

Method C: Software Control through RS-232 port

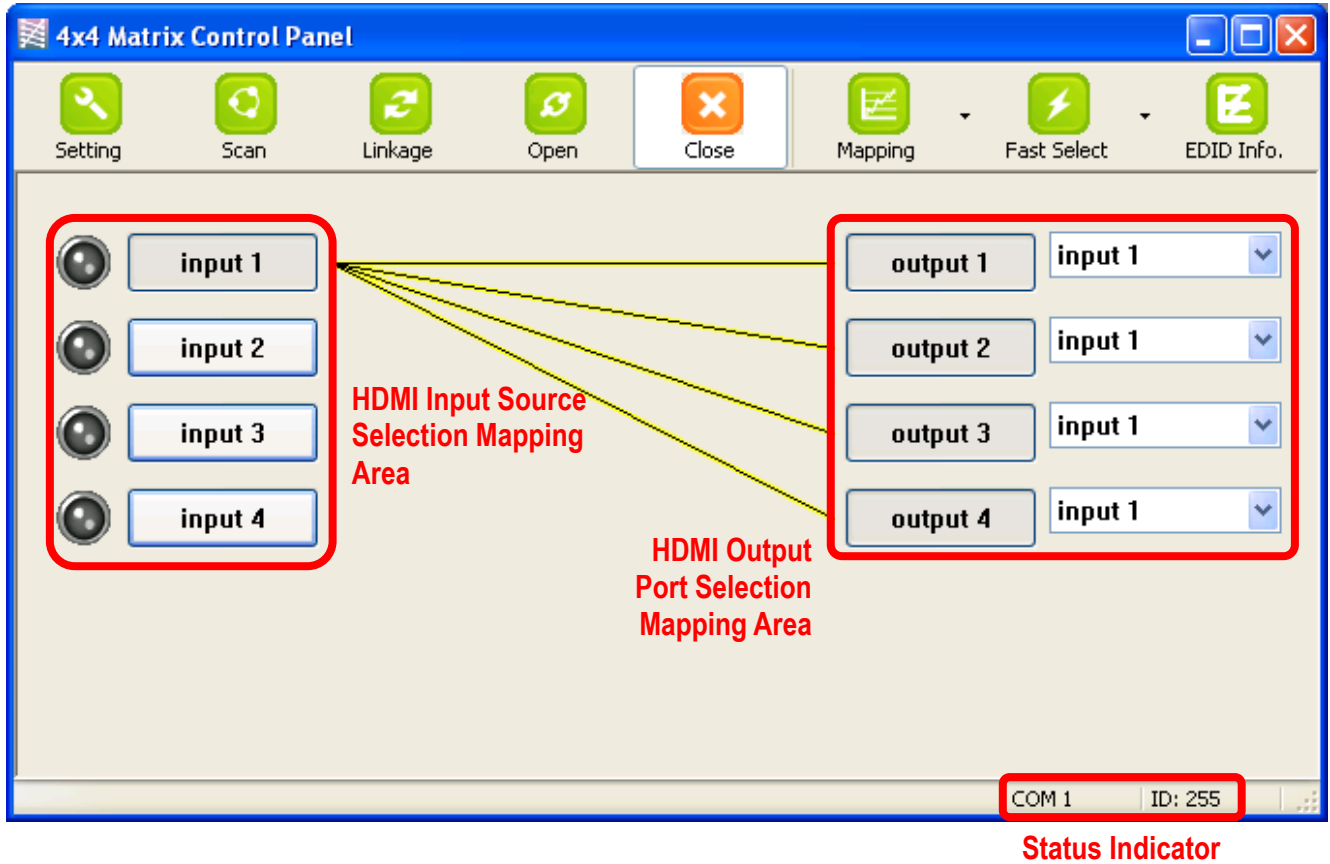

Software Control Menu

1. Setting button:



Click Get button to read back device ID.

Click Set button to write device ID.

Click Rename button to open the String Table.

In the String Table, assign the captions for each input and output port for easy recognition.

For example

Rename the Input1 to "Blu-ray player", Input2 to "Sat. receiver," input3 to "Game console," input4 to "AV receiver," input5 to "HDMI camcorder," ... etc., and rename output1 to "Conf. RM1," output2 to "Conf. RM2," output3 to "Lobby," output4 to "Main projector," ...

etc.

Click Save String Table to save the caption setting (turn effective after program restart).

Click Set Default to pop up the confirmation message below to erase the captions and reset the string table back to default setting (turn effective after program restart).

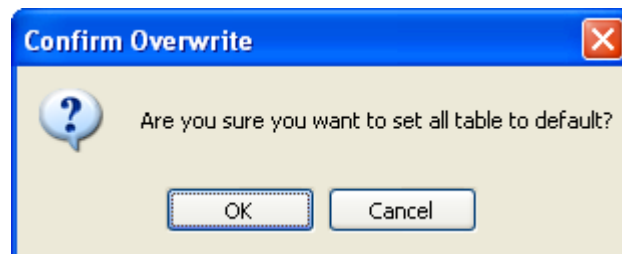
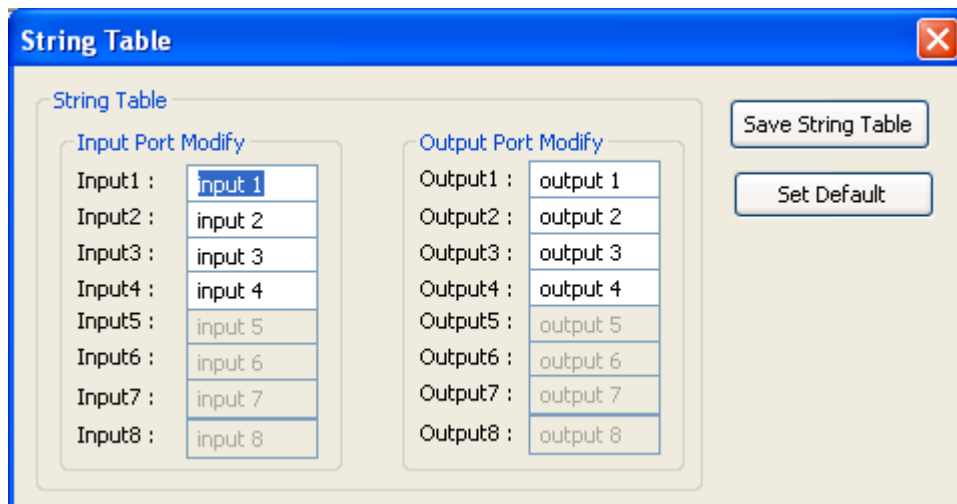

2. Scan button:

Serial Port Scan

Click Scan button, the machine will scan the all COM port and show them.

Select the RS232 serial port connected to the Matrix switch.

And set device ID 255 is for all device.

Only the same device id or 255 can get the command you sent.

Click OK. Get the new status from the Matrix switch (the port you select.)

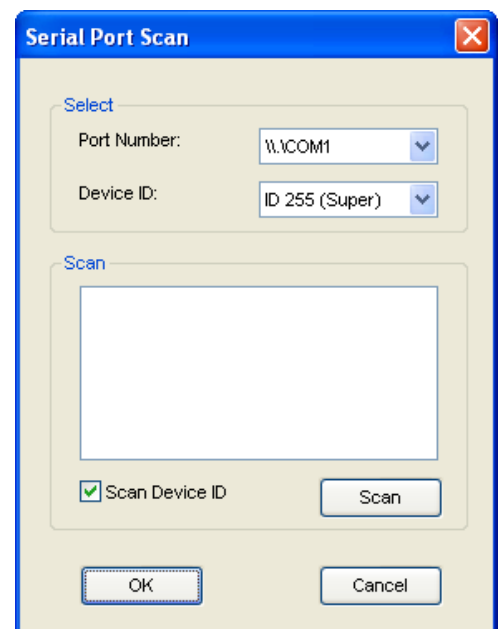

3. Linkage button:

Click Linkage button to read back all status.

4. Open/Close button:

Click this button to close or open COM port.

5. Mapping button:

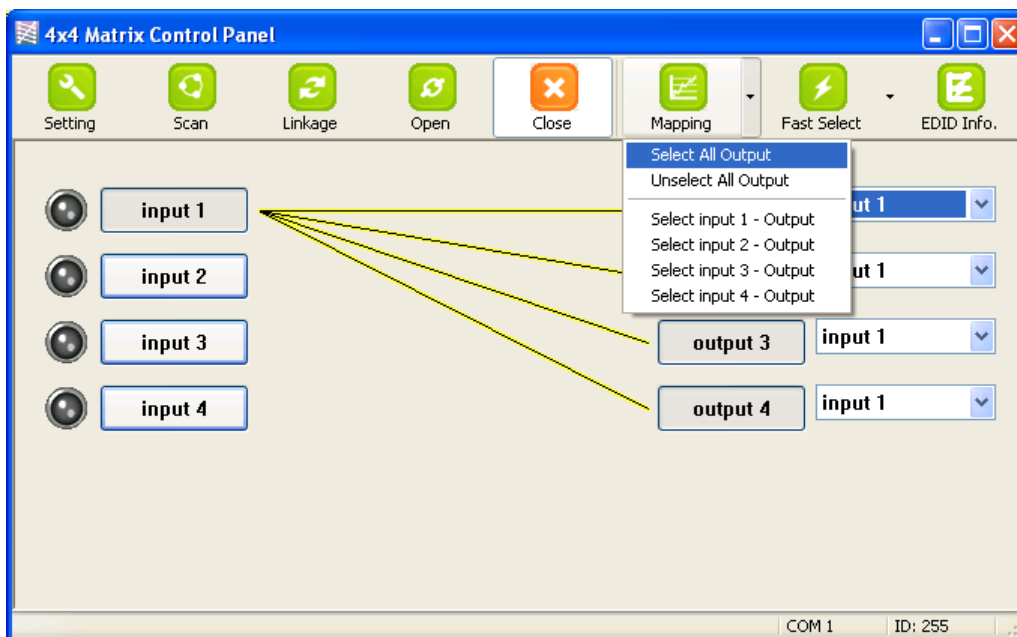

Select All Output

Select "set all output", and then select the source on main menu. You can quickly set all output to the same source.

Unselect All Output

Release output selection.

Select Input1~4-Output

Select Input Source. Then select the output port icon.

For example

Select input source 1. Then select output ports one and two. The video and audio will be sent to ports one and two.

6. Fast Select button:

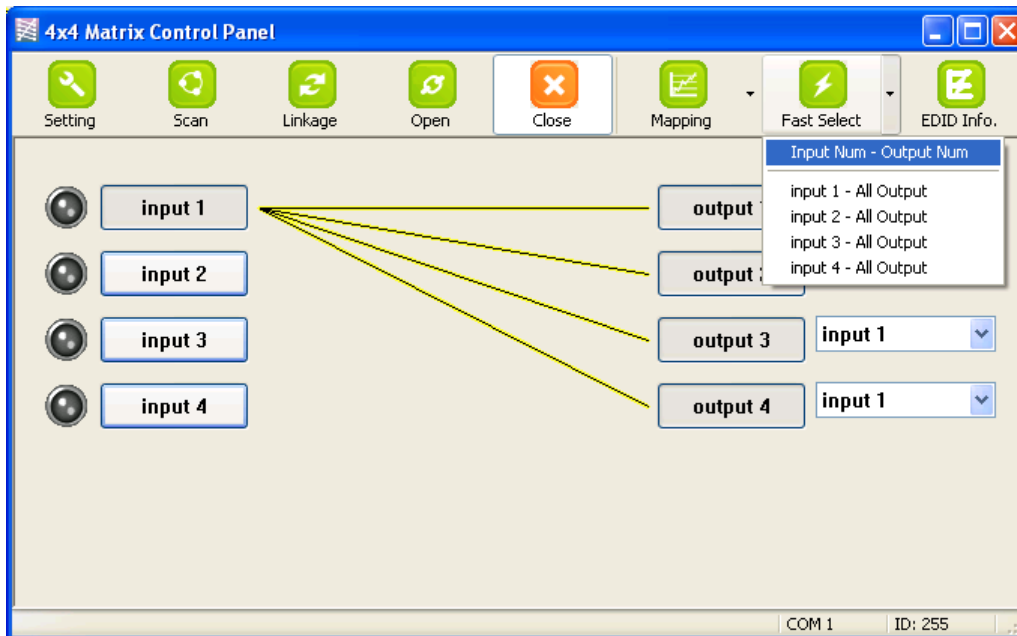

Click Fast select button. Quick setting.

Input one > Output Port one

Input two > Output Port two

.....

Click Fast select pull down menu.

Select Input Num-Output Num

Input source #1 > Output port #1

Input source #2 > Output port #2

.....

Select Input* - All Output

Send the same source to all output.

7. Output Port:

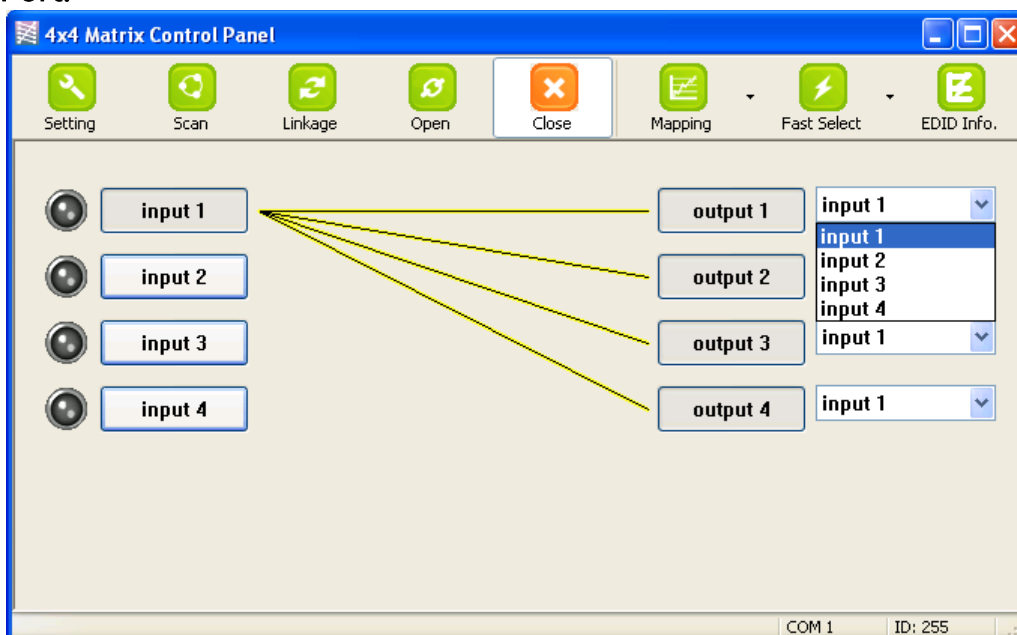

Pull down menu and select which source to be sent to this output port.

One by one setting

On main menu screen

First select input source. Then select the output ports which you want to send the video and audio from this source. When you select the input source, the source will change to gray. When you select the output port one by one, the selected output port will change to gray.

The linking line will change to yellow.

Group setting

First select output ports one by one. Then select the input source. The selected output ports change the setting at the same time.

By using Terminal:

Baud rate: 9600
Data length: 8bit
Parity check: No
Stop bit: 1

Command Set:

COMMAND	ACTION	COMMAND	ACTION
ST	System Status	VR	Firmware Version
A1	Output A selects Input 1	E1	Output E selects Input 1
A2	Output A selects Input 2	E2	Output E selects Input 2
A3	Output A selects Input 3	E3	Output E selects Input 3
A4	Output A selects Input 4	E4	Output E selects Input 4
A5	Output A selects Input 5	E5	Output E selects Input 5
A6	Output A selects Input 6	E6	Output E selects Input 6
A7	Output A selects Input 7	E7	Output E selects Input 7
A8	Output A selects Input 8	E8	Output E selects Input 8
B1	Output B selects Input 1	F1	Output F selects Input 1
B2	Output B selects Input 2	F2	Output F selects Input 2
B3	Output B selects Input 3	F3	Output F selects Input 3
B4	Output B selects Input 4	F4	Output F selects Input 4
B5	Output B selects Input 5	F5	Output F selects Input 5
B6	Output B selects Input 6	F6	Output F selects Input 6
B7	Output B selects Input 7	F7	Output F selects Input 7
B8	Output B selects Input 8	F8	Output F selects Input 8

C1	Output C selects Input 1	G1	Output G selects Input 1
C2	Output C selects Input 2	G2	Output G selects Input 2
C3	Output C selects Input 3	G3	Output G selects Input 3
C4	Output C selects Input 4	G4	Output G selects Input 4
C5	Output C selects Input 5	G5	Output G selects Input 5
C6	Output C selects Input 6	G6	Output G selects Input 6
C7	Output C selects Input 7	G7	Output G selects Input 7
C8	Output C selects Input 8	G8	Output G selects Input 8
D1	Output D selects Input 1	H1	Output H selects Input 1
D2	Output D selects Input 2	H2	Output H selects Input 2
D3	Output D selects Input 3	H3	Output H selects Input 3
D4	Output D selects Input 4	H4	Output H selects Input 4
D5	Output D selects Input 5	H5	Output H selects Input 5
D6	Output D selects Input 6	H6	Output H selects Input 6
D7	Output D selects Input 7	H7	Output H selects Input 7
D8	Output D selects Input 8	H8	Output H selects Input 8

EDID LEARNING

The EDID learning function is only necessary whenever you encounter any display on the HDMI output port that cannot play audio and video properly. Because the HDMI source devices and displays may have various level of capability in playing audio and video, the general principle is that the source device will output the lowest standards in audio format and video resolutions to be commonly acceptable among all HDMI displays. In this case, a 720p stereo HDMI signal output would be probably the safest choice. Nevertheless, the user can force the matrix to learn the EDID of the lowest capable HDMI display among others to make sure all displays are capable to play the HDMI signals normally by performing the procedures stated below.

Note

SW1-SW4 Pin#1 and Pin#2 must be set "ON" & "ON" for EDID Learning Mode



<i>DIP Switch Position</i>		<i>Video</i>	<i>Audio</i>	<i>Description</i>
<i>Pin 1</i>	<i>Pin 2</i>			
ON [↓]	ON [↓]	<i>Bypass</i>	<i>Bypass</i>	<i>EDID Learning – for learning EDID from the receiver</i>

Method: Manually connect HDMI displays to HDMI input ports

1. Power up the matrix master unit. Connect the HDMI display that its EDID needs to be learned to any of the HDMI **INPUT1 - INPUT4** port where your source device has trouble to show the picture normally.
2. To learn the display's EDID for source device connected to respective HDMI **INPUT1 - INPUT4** port, pull both pins of respective DIP switch **SW1 - SW4** up-and-down to stay at ON [] - ON [] and wait for about 5 seconds to complete the EDID learning process. You DON'T NEED to pull up the DIP switch again unless you want to learn another display's EDID by pulling both DIP switch pin-1 & pin-2 of **SW1 - SW4** up-and-down one more time.
3. Repeat step1 & step2 if you want to learn the EDID of this HDMI display on any other HDMI input ports that have same trouble playing the audio/video properly.

IR DISCRETE CODE

Default Custom Code - IR2 Code: 00 FF

Function 0x17	 0x0A	 0x0C	POWER 0x02
SOURCE SEL. 1 0x54	SOURCE SEL. 2 0x55	SOURCE SEL. 3 0x56	SOURCE SEL. 4 0x01
F1 0x57	F2 0x58	F3 0x59	F4 0x06
Output Port 1			
Input 1 - 0x18	Input 2 - 0x5B	Input 3 - 0x19	Input 4 - 0x07
Output Port 2			
Input 1 - 0x1B	Input 2 - 0x5A	Input 3 - 0x1A	Input 4 - 0x04
Output Port 3			
Input 1 - 0x0E	Input 2 - 0x0D	Input 3 - 0x12	Input 4 - 0x05
Output Port 4			
Input 1 - 0x1C	Input 2 - 0x1D	Input 3 - 0x1F	Input 4 - 0x1E

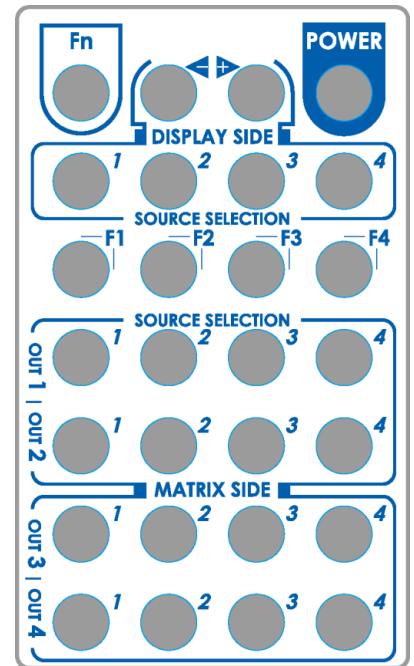

Custom Code - IR3 Code: 0x12 0x21

Custom Code: 0x12 0x21				
	Output 1	Output 2	Output 3	Output 4
Source 1	0xA1	0xB1	0xC1	0xD1
Source 2	0xA2	0xB2	0xC2	0xD2
Source 3	0xA3	0xB3	0xC3	0xD3
Source 4	0xA4	0xB4	0xC4	0xD4

Custom Code - IR4 Code: 0x13 0x31

Custom Code: 0x13 0x31				
	Output 1	Output 2	Output 3	Output 4
Source 1	0xAE	0xBE	0xCE	0xDE
Source 2	0xAD	0xBD	0xCD	0xDD
Source 3	0xAC	0xBC	0xCC	0xDC
Source 4	0xAB	0xBB	0xCB	0xDB

Note: Using terminal to set Custom Code

Example: Set custom code from 0x01 0xEE to 0x13 0x31

>> IR4 ----- command (using RS-232 terminal command mode)

>> IR4 ----- echo

Command	Custom Code
IR2	0x00 0xFF
IR3	0x12 0x21
IR4	0x13 0x31

For further information, please check the installation CD.

FAQ

Q Can every TV work with the HDMI matrix?

A Basically, the answer is YES. But if your TV can not support 1080p, please refer the EDID LEARNING section to learn EDID from your TV.

Q What is EDID? Why do I need to learn EDID?

A EDID contains the whole information of the display such as the resolution and audio setting which this display can support. Therefore, based on the EDID information, media player will pick up the most suitable resolution and audio setting to the display. In order to faithfully transmit the EDID information from display to the media player, learning EDID from display to this device is necessary.

Q What should I do to learn EDID for the matrix?

A Due to the limitation of HDMI, the source device can only output one format of video and audio. In other words, the source device cannot output 720p and 1080p video at the same time, or output stereo and surround sound at the same time. Therefore, you may need to manually setup the DIP switch for each HDMI input for desirable audio/video output format. The mechanism of EDID Learning is to pick up the HDMI display with the lowest capability among the ones you would use for this input source. For example, if user would like to play the Input-2 upon output-2, output-3 and output-4, and only output-3 cannot support 1080p [support up to 720p only], please learn the EDID from the display connected to the output-3 at the Input-2 port. Of course, if output-3 would get the HDMI signals from every HDMI input, please learn EDID information from output-3 to all four HDMI inputs. For more information about EDID Learning, please refer to EDID LEARNING section.

Q My TV can support 1080p, but why there is no audio?

A The default setting of this device is 1080p & 7.1ch audio, so there would be a problem if the TV cannot support 7.1ch audio. Please change the DIP switch of the chosen input from Default Mode to Safe Mode.

Q When I set an audio amplifier (AV receiver) between TV and the matrix to extract 7.1ch audio, but why there is still no audio?

A Basically, the default DIP switch setting of the chosen input can support 7.1ch audio, but the problem is that the EDID of the amplifier still cannot match the default setting. Therefore, the best method is to learn EDID from the amplifier directly. Please refer to EDID LEARNING section and follow the steps to learn the EDID. When learning EDID from the amplifier, user just needs to connect the matrix and amplifier. Please don't connect HDMI cable between amplifier and TV when the EDID learning is proceeding.

Q When I play the same content upon multi-displays, why only the TV equipped with amplifier can have 7.1ch audio, and the others don't have 7.1ch audio even no stereo audio?

A Due to the limitation of HDMI, the source only can choose one video and one audio format

to play, which can be either 1080p and 7.1ch or 1080p and stereo audio. It means when the user sets the matrix at 1080p and 7.1ch, the source will only play the content under this format. Therefore if the TV cannot decode 7.1ch audio, there is definitely no audio.

WARRANTY

The SELLER warrants the **AV-GM07A3-S1 4x4 HDMI Matrix Switcher with Full 3D Support** free from defects in the material and workmanship for 3 years from the date of purchase from the SELLER or an authorized dealer. Should this product fail to be in good working order within 3 years warranty period, The SELLER, at its option, repair or replace the unit, provided that the unit has not been subjected to accident, disaster, abuse or any unauthorized modifications including static discharge and power surge. This warranty is offered by the SELLER for its BUYER with direct transaction only. This warranty is void if the warranty seal on the metal housing is broken.

Unit that fails under conditions other than those covered will be repaired at the current price of parts and labor in effect at the time of repair. Such repairs are warranted for 90 days from the day of reshipment to the BUYER. If the unit is delivered by mail, customers agree to insure the unit or assume the risk of loss or damage in transit. Under no circumstances will a unit be accepted without a return authorization number.

The warranty is in lieu of all other warranties expressed or implied, including without limitations, any other implied warranty or fitness or merchantability for any particular purpose, all of which are expressly disclaimed.

Proof of sale may be required in order to claim warranty. Customers outside Taiwan are responsible for shipping charges to and from the SELLER. Cables and power adapters are limited to a 30 day warranty and must be free from any markings, scratches, and neatly coiled.

The content of this manual has been carefully checked and is believed to be accurate. However, The SELLER assumes no responsibility for any inaccuracies that may be contained in this manual. The SELLER will NOT be liable for direct, indirect, incidental, special, or consequential damages resulting from any defect or omission in this manual, even if advised of the possibility of such damages. Also, the technical information contained herein regarding the **AV-GM07A3-S1** features and specifications is subject to change without further notice.

Support

For more info or tech support

<http://www.siig.com/support>