

Universal Tabletop Monitor Riser Stand

Installation Instructions

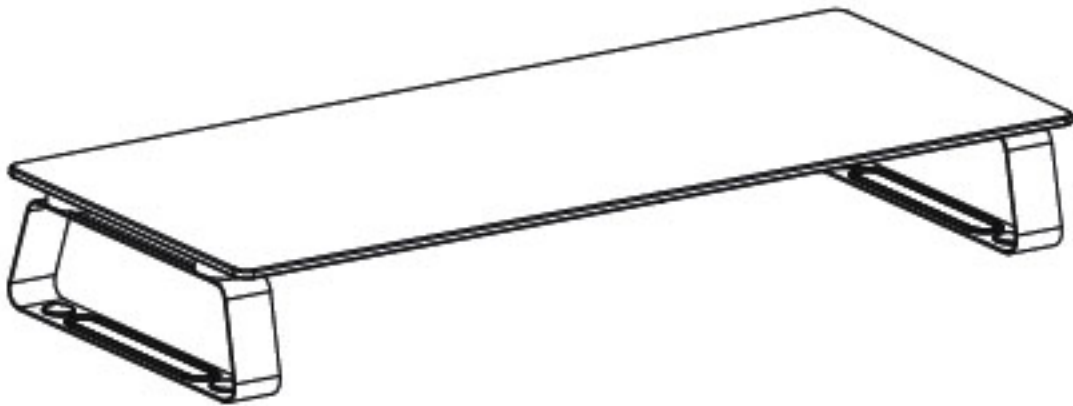

Weight Capacity: 44 LBS (Max)

Unpacking

- Carefully remove the contents and lay them out on cardboard or other protective surface
- Check package contents against the parts list to ensure that all components were received undamaged. Do not use damaged or defective parts
- Carefully read all instructions before attempting the installation

Safety Information

- Use proper safety equipment during installation
- If you don't understand the installation instructions, please consult an installation specialist
- This stand contains small parts which can act as a choking hazard if swallowed
- Do not use this product for any purpose or in any configuration not explicitly specified in these instructions

Parts List



(1x) Glass Top



(2x) Metal Support



(4x) M6x6 Bolt



(1x) 4mm Allen Key

Installation

1. Lay the glass down on cardboard or other protective surface with the mounting holes pointing up.
2. Install the Metal Support using **M6x6 Bolt** and tighten finger tight using a **4mm Allen Key**, see Figure 1.

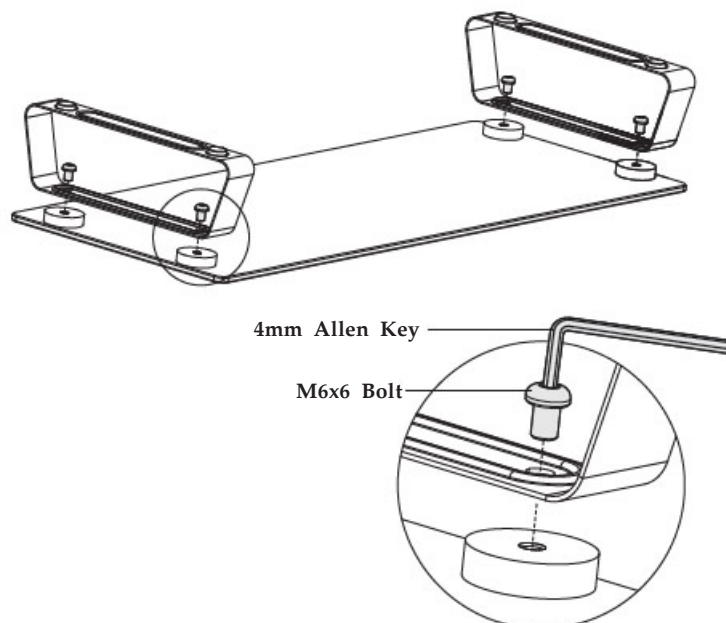
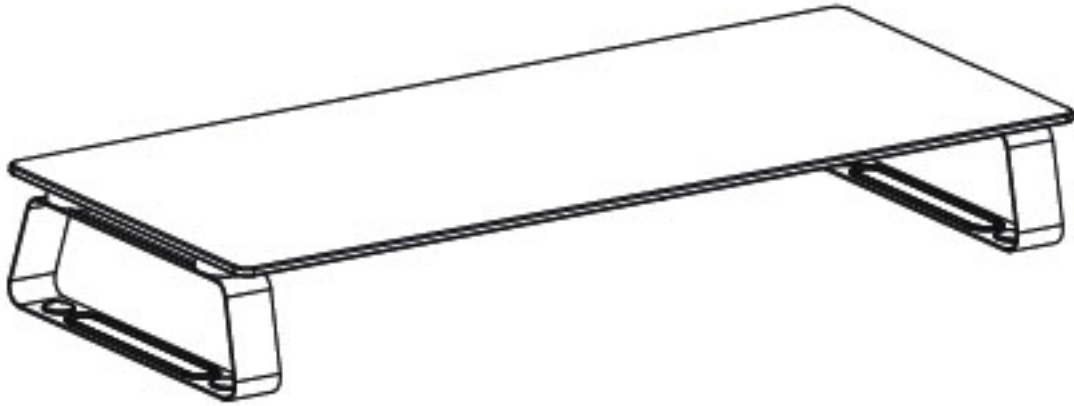

Figure 1

3. Turn the stand over and it's ready for use.



Maintenance

Check the mounting screws every two months for tightness.

Caution

- Gently place objects onto the glass top
- Do not strike the glass top with sharp objects
- Do not exceed the maximum weight capacity of 44lbs
- Do not use if the glass is chipped, cracked or damaged
- Do not place object that is hot or with rough bases directly on the glass top

Technical Support and Warranty

QUESTIONS? SIIG's **Online Support** has answers! Simply visit our web site at www.siig.com and click **Support**. Our online support database is updated daily with new drivers and solutions. Answers to your questions could be just a few clicks away. You can also submit questions online and a technical support analyst will promptly respond.

SIIG offers a 2-year manufacturer warranty with this product. This warranty covers the original purchaser and guarantees the product to be free of any defects in materials or workmanship for two (2) years from the date of purchase of the product.

SIIG will, at our discretion, repair or replace (with an identical product or product having similar features and functionality) the product if defective in materials or workmanship. This warranty gives you specific legal rights, and you may also have other rights which vary from state to state. Please see our web site for more warranty details.

If you encounter any problems with this product, please follow the procedures below.

A) If it is within the store's return policy period, please return the product to the store where you purchased from.

B) If your purchase has passed the store's return policy period, please follow the steps below to have the product repaired or replaced.

Step 1: Submit your RMA request.

Go to www.siig.com, click **Support**, then **Request A Product Replacement** to submit a request to [SIIG RMA](#) or fax a request to 510-657-5962. Your RMA request will be processed, if the product is determined to be defective, an RMA number will be issued.

Step 2: After obtaining an RMA number, ship the product.

- Properly pack the product for shipping. All accessories that came with the original package must be included.
- Clearly write your RMA number on the top of the returned package. SIIG will refuse to accept any shipping package, and will not be responsible for a product returned without an RMA number posted on the outside of the shipping carton.
- You are responsible for the cost of shipping to SIIG. Ship the product to the following address:
SIIG, Inc.
6078 Stewart Avenue
Fremont, CA 94538-3152, USA
RMA #: _____
- SIIG will ship the repaired or replaced product via Ground in the U.S. and International Economy outside of the U.S. at no cost to the customer.

About SIIG, Inc.

Founded in 1985, SIIG, Inc. is a leading manufacturer of IT connectivity solutions (including Serial ATA and Ultra ATA Controllers, FireWire, USB, and legacy I/O adapters) that bridge the connection between Desktop/Notebook systems and external peripherals. SIIG continues to grow by adding A/V and Digital Signage connectivity solutions to our extensive portfolio. All centered around the distribution and switching of A/V signals over CAT5/6, these products include matrix switches, distribution amplifiers, extenders, converters, splitters, cabling, and more.

SIIG is the premier one-stop source of upgrades and is committed to providing high quality products while keeping economical and competitive prices. High-quality control standards are evident by one of the lowest defective return rates in the industry. Our products offer comprehensive user manuals, user-friendly features, and most products are backed by a lifetime warranty.

SIIG products can be found in many computer retail stores, mail order catalogs, and e-commerce sites in the Americas, as well as through major distributors, system integrators, and VARs.

PRODUCT NAME Universal Tabletop Monitor Riser Stand

Universal Tabletop Monitor Riser Stand is a trademark of SIIG, Inc. SIIG and the SIIG logo are registered trademarks of SIIG, Inc. All other names used in this publication are for identification only and may be trademarks of their respective owners.